

**POWDER COATED STEEL
CEILING HUNG PARTITIONS
2.11A**

SPECIAL NOTES:

STRUCTURAL SUPPORTING MEMBER FURNISHED, DRILLED, AND TAPPED BY OTHERS. STEEL CHANNEL MUST BE WELDED OR FIRMLY ATTACHED TO PREVENT MOVEMENT.

LOCK NUTS ARE TO BE WRENCH TIGHTENED ON STUDS. DO NOT HAND TIGHTEN.

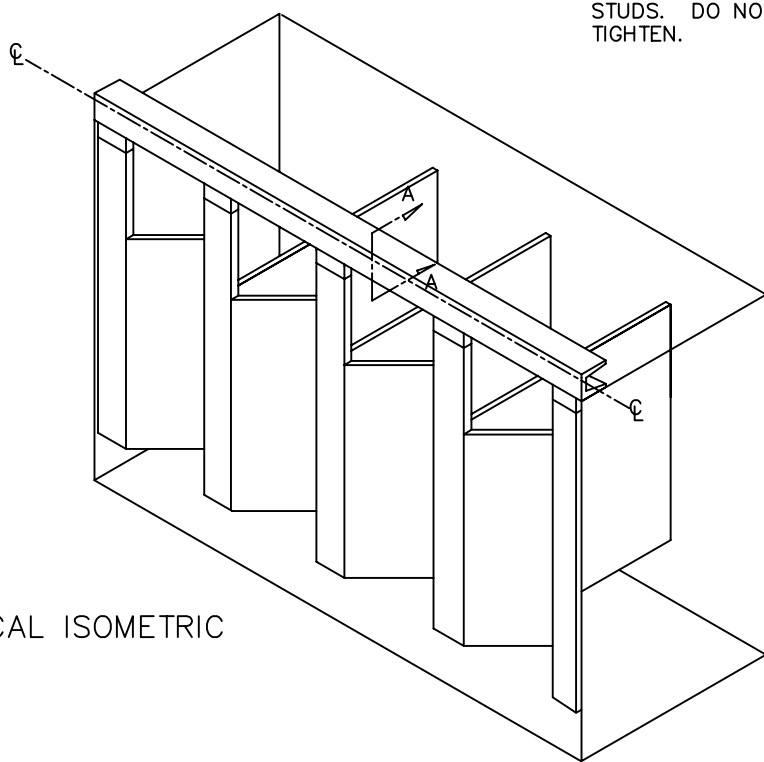

TYPICAL ISOMETRIC

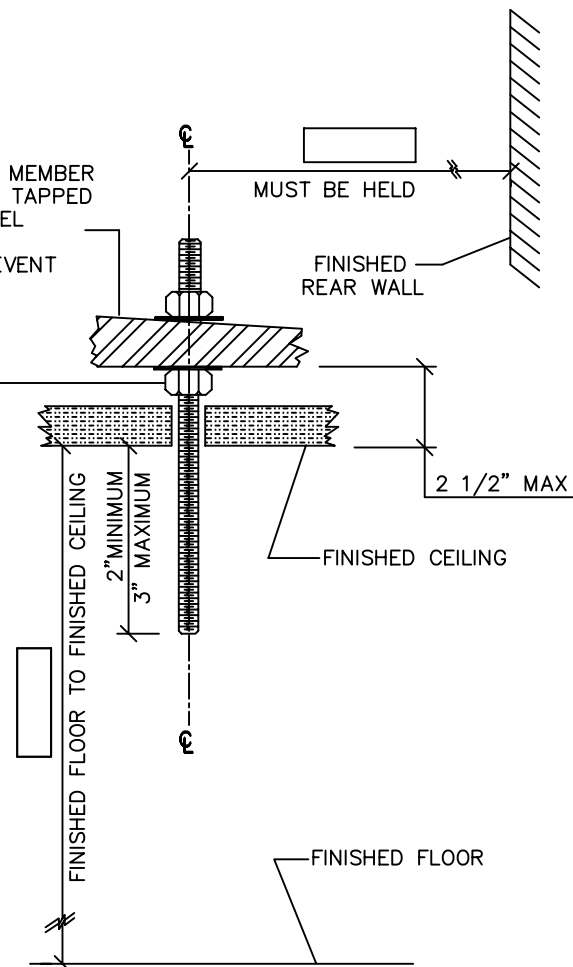

SECTION A-A

SPECIAL NOTES:

- 1) CAREFULLY ERECT SUPPORTING STRUCTURAL MEMBER IN RELATION TO FINISHED SIDE, BACK WALLS AND FINISHED CEILING HEIGHT TO DIMENSIONS SHOWN ON SHOP DRAWINGS.
- 2) DRILL HOLES ACCURATELY IN SUPPORTING STRUCTURAL MEMBER FROM LOCATIONS SHOWN ON PUNCHING LAYOUT ON SHOP DRAWINGS.
- 3) INSTALL STUDS (3/8" DIAMETER THREADED RODS) WITH LOCK NUTS AND WASHERS BEFORE APPLYING FINISHED CEILING.
- 4) FINISHED CEILING TO BE INSTALLED ONLY AFTER STUDS ARE IN PLACE. HOLD FINISHED CEILING AS CLOSE TO STRUCTURAL MEMBER AS POSSIBLE.
- 5) ACCURATE PARTITIONS CORP. SHALL NOT WARRANTY THE INSTALLATION IF THE DISTANCE BETWEEN THE STRUCTURAL STEEL AND THE FINISHED CEILING EXCEEDS 2 1/2".
- 6) CEILING HUNG COMPARTMENTS REQUIRE COORDINATION BETWEEN SEVERAL SUBCONTRACTORS AS OUTLINED ON THIS SHEET.

CEILING HUNG PARTITIONS

REV 12/04